



IMPORTANT FOR FUTURE REFERENCE

Please complete this information and retain this manual for the life of the equipment:

Model #: _____

Serial #: _____

Date Purchased: _____

Service & Parts Manual
Covering the
**SPINFRESH™ Option for
Solstice Fryers**

ENGLISH



FOR YOUR SAFETY

DO NOT store or use gasoline or other flammable vapors or liquids in the vicinity of this or any other appliance. Do not spray aerosols in the vicinity of this appliance while it is in operation.

WARNING

Improper installation, alteration, service or maintenance can cause property damage, injury or death. Read the installation, operating and maintenance instructions thoroughly before installing or servicing this equipment.

WARNING

Installation, maintenance and repairs should be performed by a Pitco Authorized Service and Parts (ASAP) company technician or other qualified personnel. Installation, maintenance or repairs by an unauthorized and unqualified personnel will void the warranty.

WARNING

Installation and all connections must be made according to national and local regulations and codes in force.

WARNING

During the warranty period if a customer elects to use a non-original part or modifies an original part purchased from Pitco and/or its Authorized Service and Parts (ASAP) companies, this warranty will be void. In addition, Pitco and its affiliates will not be liable for any claims, damages or expenses incurred by the customer which arises directly or indirectly, in whole or in part, due to the installation of any modified part and/or received from an unauthorized service center.

WARNING

This appliance, when installed, must be electrically grounded in accordance with local codes, or in the absence of local codes, with the National Electrical Code, ANSI/NFPA 70, or the Canadian Electrical Code, CSA C22.2, as applicable.

WARNING

Adequate means must be provided to LIMIT the movement of this appliance without depending on the gas or electrical cord connection. Single appliances equipped with legs must be stabilized by installing anchor straps. All appliances equipped with casters must be stabilized by installing restraining chains.

WARNING

An appliance equipped with casters and a flexible gas line must be connected to the gas supply with a quick disconnect device. The quick disconnect must comply with ANSI Z21.41.

WARNING

DO NOT alter or remove structural material on the appliance to accommodate placement under a ventilation hood.

WARNING

This appliance is intended for professional use only and should be operated by fully trained and qualified personnel.

WARNING

If the appliance is equipped with a power cord and it is damaged, it must be replaced by a Pitco Authorized Service and Parts (ASAP) company technician, or a similarly qualified person in order to avoid a hazard.

WARNING

The power supply must be disconnected before servicing, maintaining or cleaning this appliance.

WARNING

The appliance is NOT jet stream approved. DO NOT clean the appliance with a water jet.

WARNING

DO NOT attempt to move this appliance or transfer hot liquids from one container to another when the unit is at operating temperature or filled with hot liquids. Serious personal injury could result if skin comes in contact with the hot surfaces or liquids.

WARNING

DO NOT sit or stand on this appliance. The appliance's front panel, tank, splash back, tank cover, workshelf, drain board is not a step. Serious injury could result from slipping, falling or contact with hot liquids.

WARNING

NEVER use the appliance as a step for cleaning or accessing the ventilation hood. Serious injury could result from slips, trips or from contacting hot liquids.

WARNING

The oil/shortening level should NOT fall below the minimum indicated level line at any time. The use of old shortening can be dangerous as it will have a reduced flash point and be more prone to surge boiling.

WARNING

The contents of the crumb catch and/or filter pan of any filter system must be emptied into a fireproof container at the end of the frying operation each day. Some food particles can spontaneously combust into flames if left soaking in certain oil/shortening materials.

WARNING

Completely shut the appliance down when shortening/oil is being drained from the appliance. This will prevent the appliance from heating up during the draining and filling process. Serious injury can occur.

WARNING

This appliance is intended for indoor use only.

WARNING

DO NOT operate appliance unless all panels and access covers are attached correctly.

WARNING

It is recommended that this appliance be inspected by a qualified service technician for proper performance and operation on a yearly basis.

WARNING

There is an open flame inside this appliance. The unit may get hot enough to set nearby materials on fire. Keep the area around the appliance free from combustibles.

WARNING

DO NOT supply the appliance with a gas that is not indicated on the data plate. If you need to convert the appliance to another type of fuel, contact your dealer.

WARNING

DO NOT use an open flame to check for gas leaks!

WARNING

If gas flow to appliance is interrupted, or pilots extinguish, wait 5 minutes before attempting to relight the pilot to allow any residual gas in appliance to dissipate. Do not attempt to use this appliance during a power outage.

WARNING

Ensure that the appliance can get enough air to keep the flame burning correctly. If the flame is starved for air, it can give off a dangerous carbon monoxide gas. Carbon monoxide is a clear odorless gas that can cause suffocation.

WARNING

Never add oil to the appliance when it is at operating temperature. Splashing hot oil can cause severe injuries.

WARNING

DO NOT supply the appliance with a gas that is not indicated on the data plate. If you need to convert the appliance to another type of fuel, contact your dealer.

WARNING

Never add water to hot oil. Violent boiling can occur causing severe injury.

WARNING

Excessive loading or loading of over wet food can cause surge boiling. The maximum cooking load must not exceed (14T-1.5lbs(0.68kg), 14-3 lbs (1.36 kg), 18-5 lbs (2.27 kg)).

WARNING

A country approved all pole circuit breaker with a minimum open contact gap of 3mm must be used for proper installation. (CE countries)

TABLE OF CONTENTS

1	Fire Safety Systems	5
2	Operation	5
3	Troubleshooting	5
4	Basket Engagement	6
5	Field Upgrade	8
6	Basket Lift Relay Logic	9
7	<i>SPIN</i> FRESH Diagnostic Mode	9
8	Exploded parts	9
8.1	Superseded basket Lift Assembly built before September 2012	10
8.2	Basket Lift Assembly built after September 2012	12
8.3	Superseded Enclosure Assembly built before September 2012	14
8.4	Enclosure Assembly built after September 2012	16
8.5	Superseded Cover & Damper Assembly built before September 2012	18
8.6	Cover Assembly built after September 2012	19
8.7	Miscellaneous Parts	20
8.8	Basket Assembly	21
8.9	Bottom Assembly	22
8.10	Splash Back Assembly	23
9	Basket Lift Wiring Diagram	24
10	Schematic	25

1 Fire Safety Systems

If your appliance is equipped with *SPINFRESH™*, the tank enclosure can interfere with the performance of pre-existing fire safety systems. Modifications to the fire safety system should be performed by a professional who is qualified in installing, designing and maintaining your fire safety system prior to operating any *SPINFRESH™* appliance.

WARNING

Replacing or adding appliances under a pre-existing fire safety system may require modifications to the system. ALWAYS contact a professional who is qualified in installing, designing and maintaining your fire safety system to assure that any appliances located under the fire safety system are adequately protected.

2 Operation

If the appliance is equipped with *SPINFRESH™*, place the basket directly onto the basket lift pin and close the lid prior to starting the timer(s). The basket(s) will be lowered into the cook tank when the timer cycle starts. At the end of the preset cooking time, the basket lift will raise the basket out of the cook tank and spin the basket to remove excess oil. The lid may be opened during the cooking cycle but must be closed prior to the spin cycle.

WARNING

NEVER open the lid or reach into the *SPINFRESH™* enclosure during the spin cycle. Serious injury could result.









3 Troubleshooting

Issue	Possible Causes
Basket does NOT travel up or down	Basket lift Circuit breaker is tripped Loose power connection to basket lift Basket lift transformer Basket lift driver board Damaged/improperly wired relay Basket lift actuator
Basket does NOT spin	Basket lift Circuit breaker is tripped Loose power connection to basket lift Lid magnet switch Power supply Stepper motor driver board Stepper motor
Basket spins erratically	Product is not placed evenly in the basket. Bottom plate (holds basket straight in appliance) Improper basket engagement

4 Basket Engagement

This procedure is to check the basket engagement during the spin cycle and make any adjustments if required.

WARNING
Oil/shortening must completely cover the heat tubes or heating elements at all times while appliance is on.

- ❑ Press  to turn the appliance ON.
- ❑ Press       to enter spin diagnostic mode.
- ❑ Press  to raise the basket to the highest position.
- ❑ Check the basket drive pin's location within the drive coupling. Adjust basket drive pin position as described if required.



GOOD



BAD

- ❑ Check to assure that the top plate springs are not extending while the basket drive pin is in the coupling. Adjust basket drive pin position as described if required.

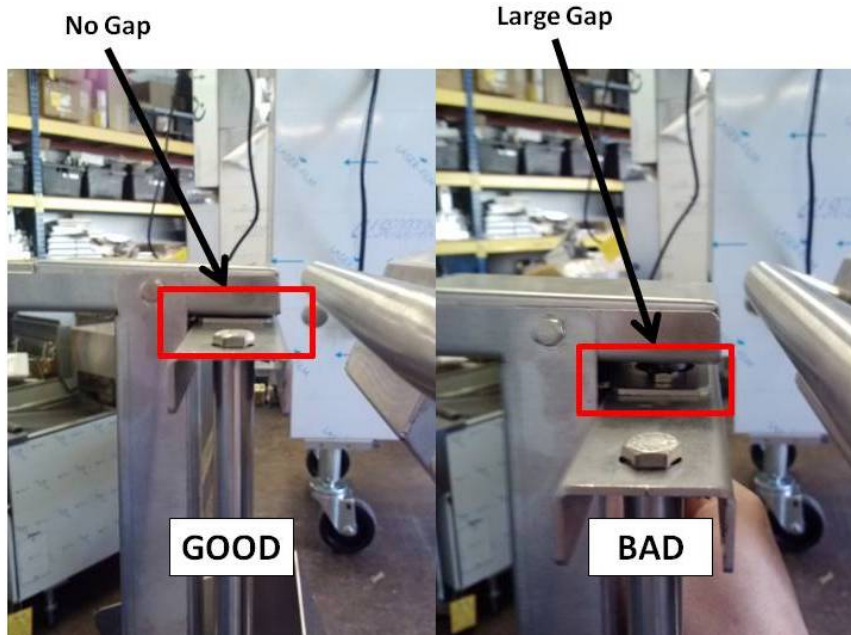



NOTICE

Do NOT rotate the proximity switch during this procedure. The rotation of the switch is critical to accurately sensing the basket lift position.

If the basket drive pin position needs adjustment.

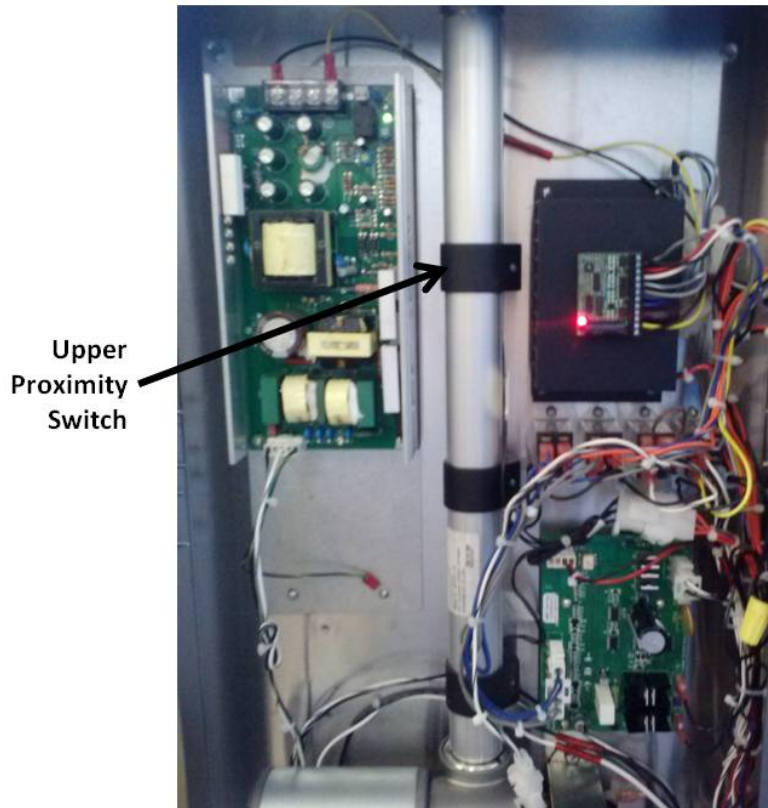
- While holding the upper proximity switch in place, use a small screwdriver to loosen screw on the switch. Move the switch up and down to adjust the upper position. Move the proximity switch the same distance that the basket pin is away from its ideal location. After repositioning the switch, use a small screwdriver to tighten the screw on the proximity switch to secure it in place.



- Press  to move the basket to the middle position.
- After the basket has moved to the middle position, press  to move the basket to the newly defined upper position.
- Repeat the previous steps until the basket drive pin is positioned correctly within the drive coupling.

5 Field Upgrade

In February of 2013, various improvements to the SPINFRESH™ option were made available as a field upgrade kit. Refer to the diagram below to identify if the appliance has been upgraded or not. If the appliance can be upgraded, contact the factory to order the appropriate upgrade kit.

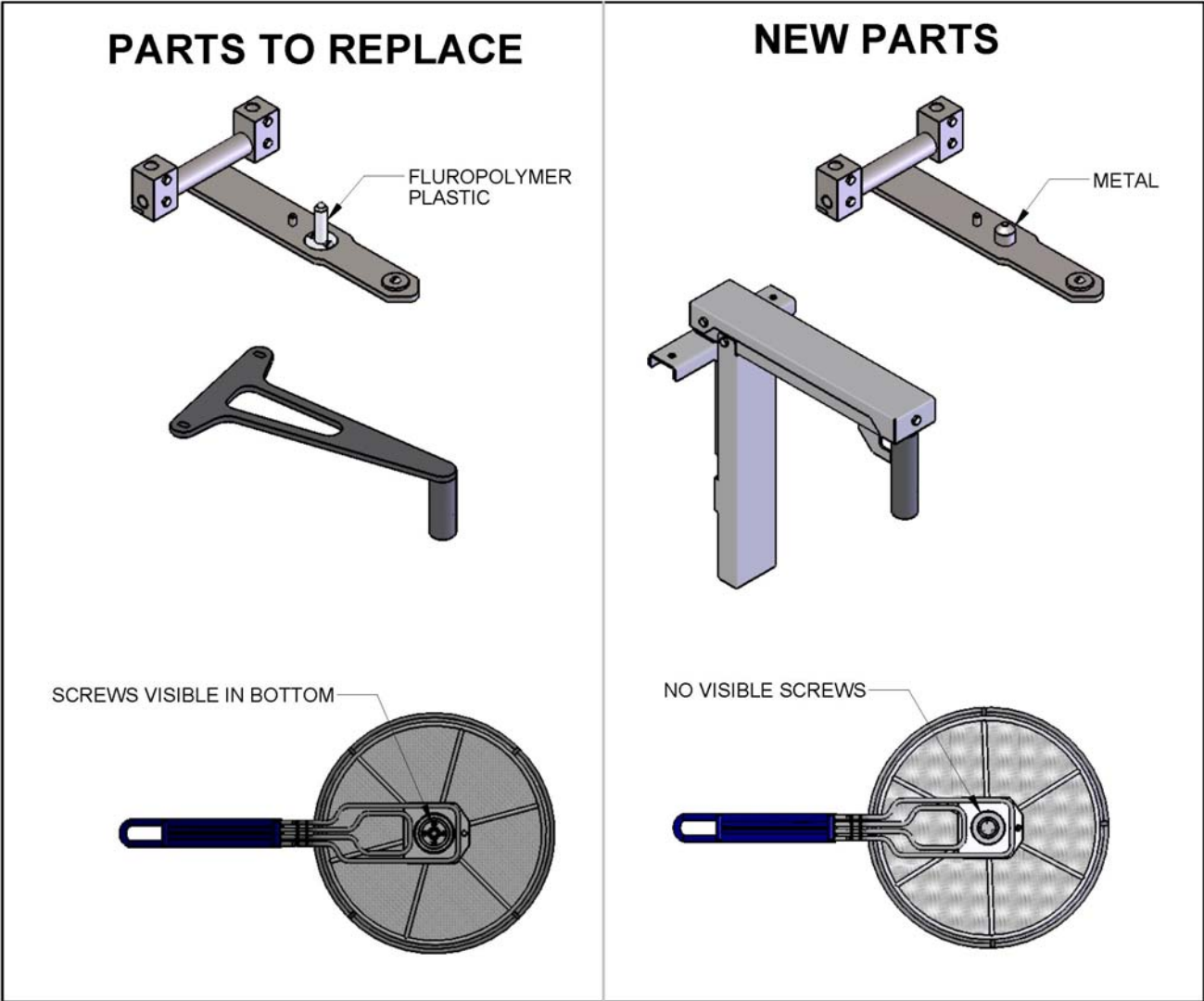

Upgrade kit part numbers:

Kit No.	Models Covered	Item 1	Item 2	Item 3
B8705901-CL	SG14R, SSH55	B5609901-C	B5608802	B4516001-C
B8705902-CL	SG14	B5609902-C		
B8705903-CL	SE14	B5609903-C		
B8705904-CL	SGH50, SEH50	B5609904-C		

6 Basket Lift Relay Logic

Relay	Controlled by	Switches	
K1	Spin (Upper) Position Proximity Switch	Signal to the I-12 computer	Signal to Basket lift driver board
K2	Cook (Lower) Position Proximity Switch	Signal to the I-12 computer	Signal to Basket lift driver board
K3	K4 Relay	Electrically Brakes the actuator movement	
K4	Signal from the I-12 Computer	Start signal to the basket lift driver board	K3 Relay

7 SPINFRESH Diagnostic Mode

Spin Diagnostics	
	Press
Step 1. Enter Factory Programming	P-1-9-9-3
Step 2. Enter Spin Diagnostics	9
Spin Diagnostics	
	Button
Turns motor on & off	L
Increases motor speed	1
Decreases motor speed	2
Changes motor direction	3
Vibrate (not used)	4
Indicator light: door open/closed	5
Indicator light: cook position	6
Indicator light: load position	7
Indicator light: spin position	8
Move to cook position	9
Move to load position	0
Move to spin position	R

8 Exploded parts

8.1 Superseded basket Lift Assembly built before September 2012

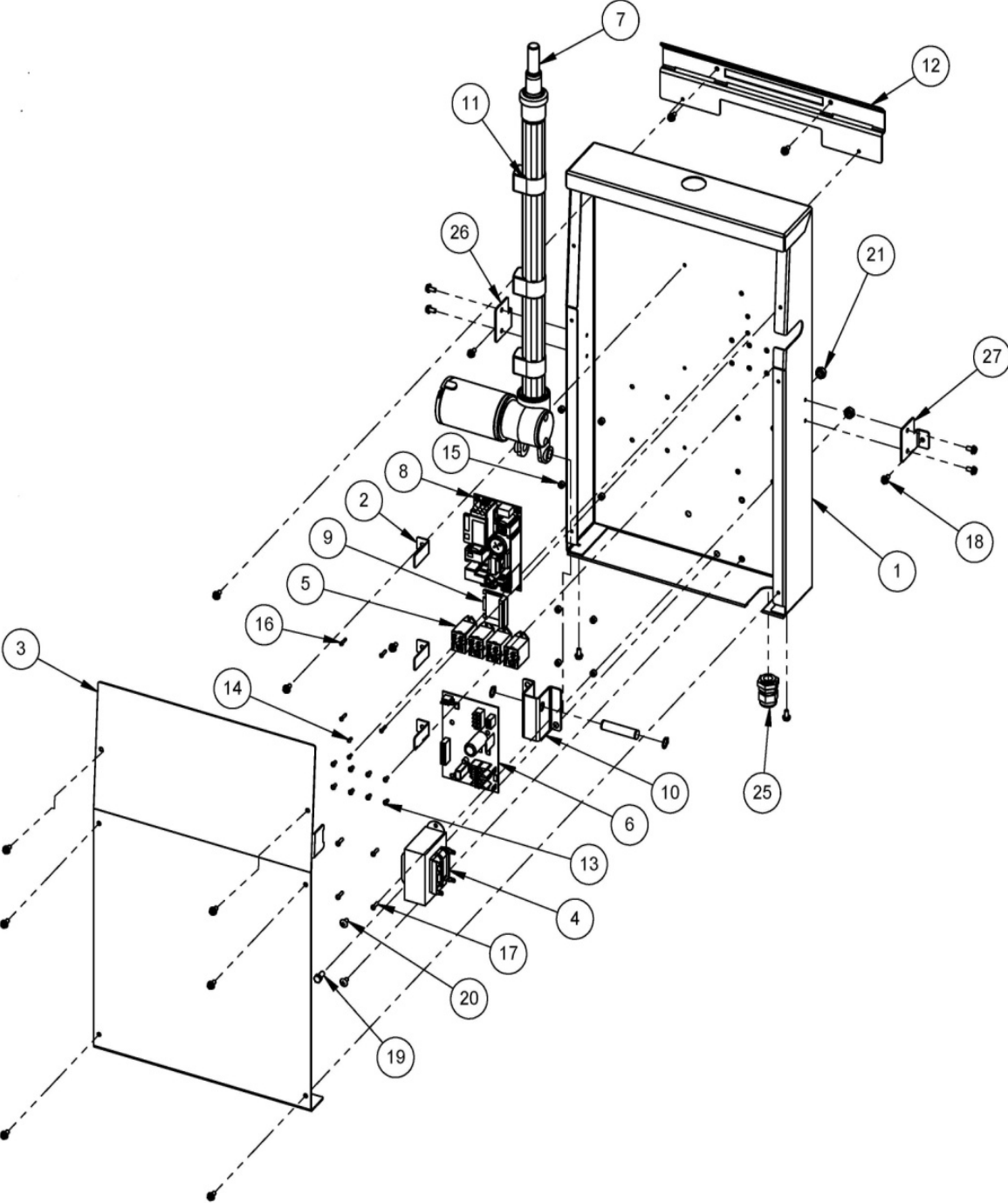

See next page for parts list.

Superseded Basket Lift Assembly built before September 2012

ITEM #	PART NO.	DESC.
1	A5625802	BSKT LFT,BOX SPINFRESH
2	A5625901	BSKT LFT,MAG SW SPRT CLIP S
3	A5626002	BSKT LFT,BOX COV ACTR MOD S
4	PP10429-M	XFMR,80VA 120/208/240V TO 2
5	PP11068	RELAY,24VDC DPDT MTG TAB
6	60134001	CNTRL,BASKT LIFT DRIVER BOA
7	60134305	ACTR,25 3.3-9.4 24VDC 1IPS SPIN
8	60174101	SPLY,SWITCHING PWR 2.6A 48V
9	60174001	DRVR,STEPPER MOTOR 3.5A 50V
10	A5626202	BSKT LFT,ACTR C-CHAN BRKT S
11	60136901	CLAMP, BASKET LIFT LIMIT SWITCH
12	A5626302	B/L, TOP SPRT DRIP GRD
13	PP10686	SCR, 6-32 X 1/4 RDH PHILLIPS ZN
14	PP10266	SCR, 4-40 X 1/4 RDH ZN
15	60177502	STAND-OFF, #6 X 1/2 NYLON
16	PP10674	SCR, 6-32 X 5/8 RDH PHILLIPS ZN
17	PP10689	SCR, 6-32 X 1/2 RDH PHILLIPS ZN
18	PP10023	SCR, 10-24 X 3/8 SLF TAP
19	P0113300	SCR, 1/4-20 X 1/2 HHC SST
20	PP10693	SCR, 10-24 X 3/8 TH PHILLIPS ZN
21	P0093300	NUT, HEX (KEP) 1/4-20 ZN
25	P6071140	CONN LIQUID TIGHT 3/8
26	A5626102	B/L,SD MTG BRKT LH
27	A5626104	B/L,SD MTG BRKT RH

8.2 Basket Lift Assembly built after September 2012

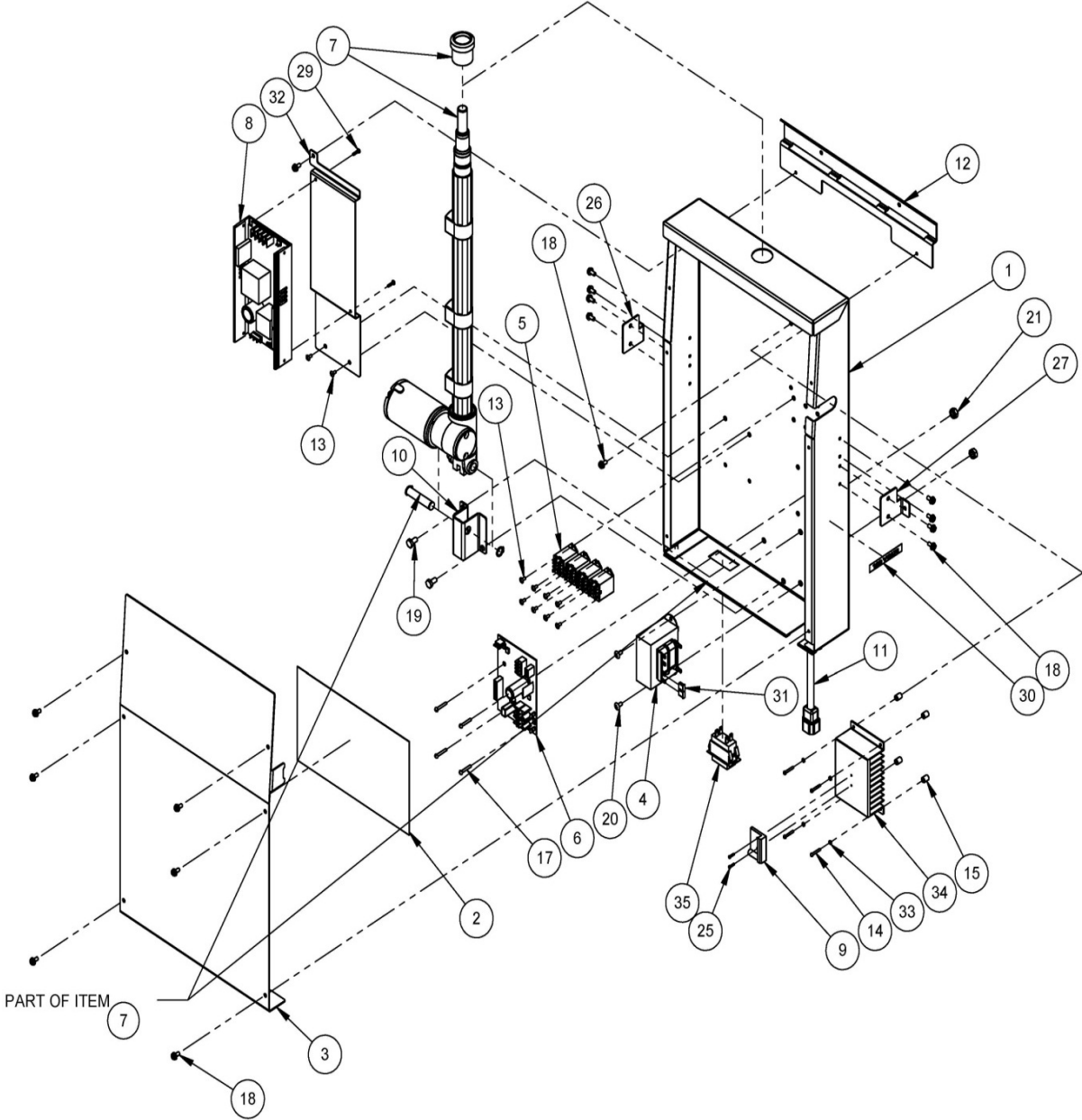

See next page for parts list.

Basket Lift Assembly built after September 2012

B56092xx, Complete assembly

ITEM NO.	PART NO.	DESCRIPTION	QTY
1	A5625802	BASKET LIFT, BOX	1
2	700324-10	LABEL, SCHEMATIC WIRING SG,SE SPINFRESH	1
3	A5626002	BASKET LIFT, BOX COVER ACTUATOR MODULAR SG	1
4	PP10429-M	TRANSFORMER, 80VA 120-208-240V TO 24V MCI	1
5	PP11068	RELAY, 24VDC DPDT WITH MOUNTING TABS	4
6	60134001	CNTRL,BASKT LIFT DRIVER BOARD	1
7	60134305	ACTUATOR, 25 3.3-9.4 245VDC 1IPS SPIN	1
8	60179101	POWER SUPPLY, 48 VDC 4.2A SPIN	1
9	60174001	DRIVER, STEPPER MOTOR 3.5A 50V	1
10	A5626202	BASKET LIFT, ACTUATOR C-CHANNEL BRKT	1
11	60133901	CORD, 16-3 AWG, IEC320M PLUG 28.0"	1
12	A5626302	BASKET LIFT, TOP SPRT DRIP GUARD BRACKET	1
13	PP10687	SCREW, 6-32 X .313 THRUSS HEAD PHILLIPS ZN	10
14	PP11351	SCREW, 4-40 X .750 ROUND HEAD SLOTTED ZN	4
15	60177503	STAND-OFF, NYLON LENGTH .3750 OD .250 #4 SCREW	4
16	B6797901	WIRING, POWER SUPPLY UPGRADE SPIN	1
17	P0006100	SCREW, 6-32 X .875 ROUND HEAD SLOTTED ZN	4
18	PP10023	SCREW, 10-24 X .375 SELF TAPPING	18
19	P0113300	SCREW, .250-20 X .500 HEX HEAD SST	2
20	PP10693	SCREW, 10-24 X .375 THRUSS HEAD PHILLIPS ZN	2
21	P0093300	NUT, HEX KEP .250-20 ZN	2
22	P0092500	NUTSERT, 10-24 UNC	2
23	P0091400	NUTSERT, 6-32 UNC	14
24	60092101	NUTSERT, 4-40 UNC	4
25	60044801	SCREW, SOCKET HEAD 2-56 X .375	2
26	A5626102	BASKET LIFT, SIDE INSERT BRACKET LH	1
27	A5626104	BASKET LIFT, SIDE INSERT BRACKET RH	1
28	B6795001	WIRING, SPINFRYER BASKET LIFT ASSEMBLY	1
29	60070601	SCREW, M3 X 0.5mm X 12mm	2
31	60127201	CAP,TAB .187 SERIES	2
32	A5626901	BRACKET, POWER SUPPLY SPIN BL	1
33	60180601	SHOULDER WASHER, SHORT BARREL #4	4
34	60180301	HEAT SINK, SPIN BL	1
35	60078502	CIRCUIT BREAKER, ROCKER DPST 250V 5A	1

8.3 Superseded Enclosure Assembly built before September 2012

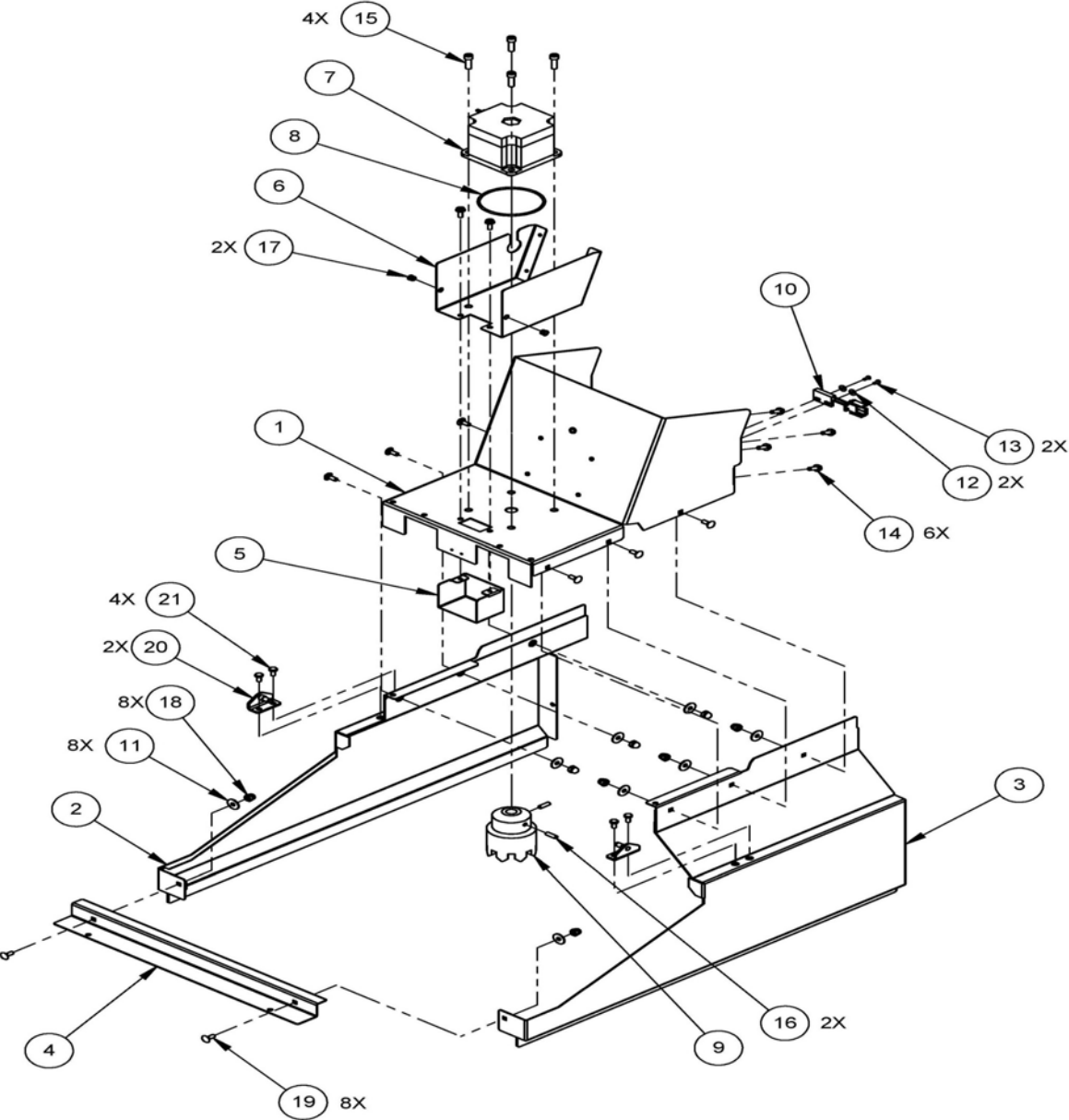

See next page for parts list.

Superseded Enclosure Assembly built before September 2012

ITEM #	PART NO.	DESCRIPTION	SSH55 SG14	SE14	S*H50
1	B3335501	TANK, ENCLOSURE TOP WELDMENT	X		
	B3335502	TANK, ENCLOSURE TOP WELDMENT		X	
	B3335503	TANK, ENCLOSURE TOP WELDMENT			X
2	B3335601	TANK, ENCLOSURE SIDE WELDMENT LH	X		
	B3335603	TANK, ENCLOSURE SIDE WELDMENT LH		X	
	B3335605	TANK, ENCLOSURE SIDE WELDMENT LH			X
3	B3335602	TANK, ENCLOSURE SIDE WELDMENT RH	X		
	B3335604	TANK, ENCLOSURE SIDE WELDMENT RH		X	
	B3335606	TANK, ENCLOSURE SIDE WELDMENT RH			X
4	A3366202	TANK, ENCLOSURE FRONT	X	X	X
5	A3366302	TANK, ENCLOSURE MAGNET BOX BODY	X	X	X
6	A3366402	TANK, ENCLOSURE MOTOR BOX BODY	X		
	A3366404	TANK, ENCLOSURE MOTOR BOX BODY		X	X
7	60174301	MOTOR, STEPPER NEMA34 2.8A SURE STEP	X	X	X
8	60068317	O-RING, VITON 3.063 OD, 2.875 ID	X	X	X
9	A5075001	COUPLE, DRIVE	X	X	X
10	B5305001	ELECTRICAL ASSEMBLY, DVI	X	X	X
11	60022903	WASHER, FLAT #10 11/16 OD SST	X	X	X
12	60022908	WASHER, FLAT #4 SST	X	X	X
13	60088011	SCREW, 4-40 X .250 HEX HEAD SST	X	X	X
14	P0075400	SCREW, 10-24 X .500 SELF TAPPING	X	X	X
15	PP11369	SCREW, SOCKET HEAD .250-20 X .750	X	X	X
16	PP10950	SET SCREW, SLOTTED .250-20 UNC, .375L	X	X	X
17	P0092500	NUTSERT, 10-24 UNC	X	X	X
18	P0142000	NUT, ACORN WITH CENTERLOCK 10-24 SST	X	X	X
19	60135703	BOLT, 10-24 X 3/8 CARRIAGE SST	X	X	X
20	B2104601	TK COV, DMPR BRKT RR WLDMT	X	X	X
21	60088012	SCREW, 10-24 X .375 HEX HEAD SST	X	X	X

8.4 Enclosure Assembly built after September 2012

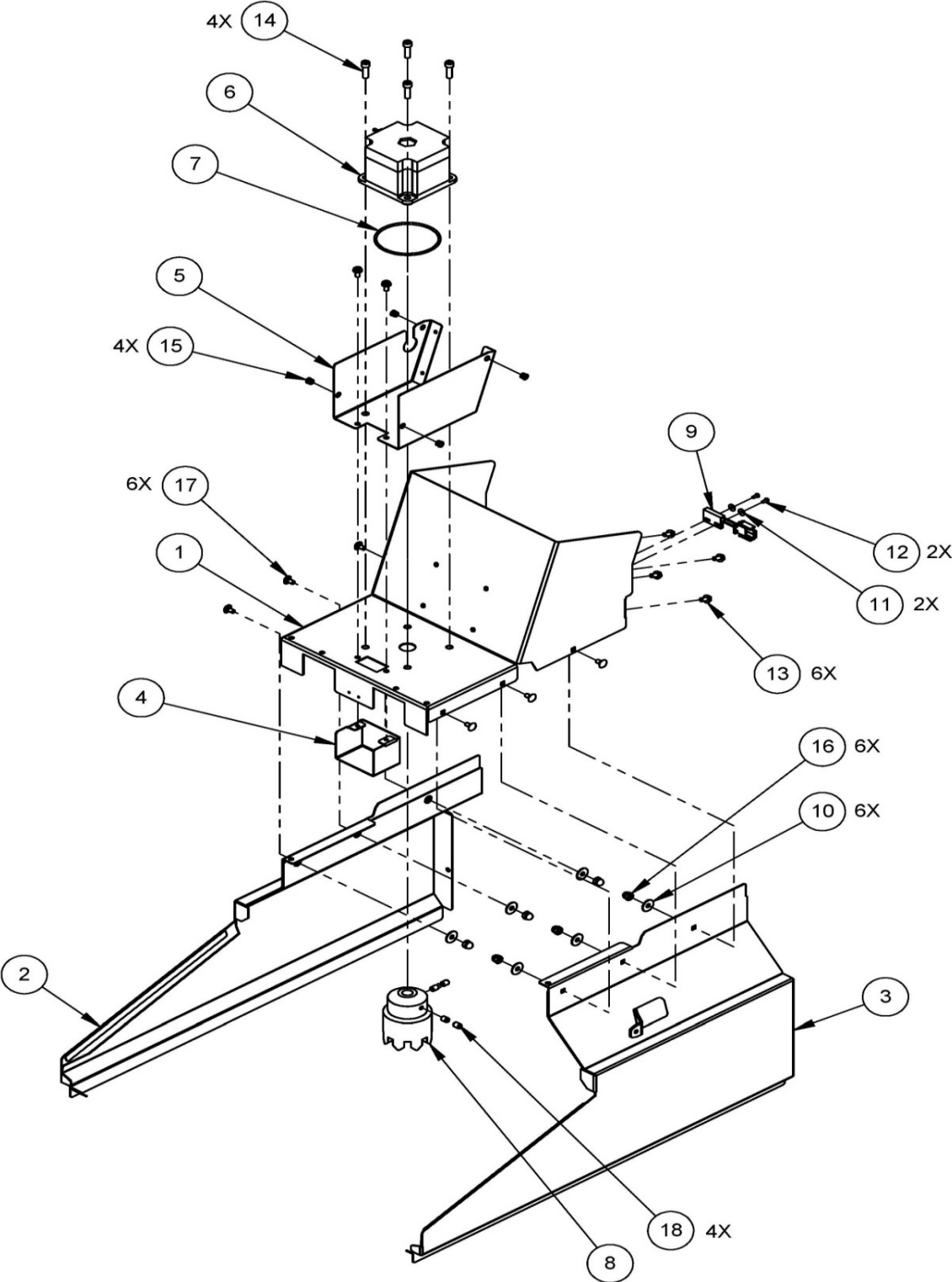

See next page for parts list.

Enclosure Assembly built after September 2012

B33354xx, Complete assembly

ITEM NO.	PART NO.	DESCRIPTION	SG14 SSH55	SE14	S*H50
1	B3335503	TANK, ENCLOSURE TOP WELDMENT S*H50 SPIN	-	-	X
1	B3335502	TANK, ENCLOSURE TOP WELDMENT SE14 SPIN	-	X	-
1	B3335501	TANK, ENCLOSURE TOP WELDMENT SG14* SPIN	X	-	-
2	B3335901	TANK, ENCLOSURE SIDE WELDMENT SG* SPIN LH	X	-	-
2	B3335903	TANK, ENCLOSURE SIDE WELDMENT SE* SPIN LH	-	X	-
2	B3335905	TANK, ENCLOSURE SIDE WELDMENT S*H50 SPIN LH	-	-	X
3	B3335906	TANK, ENCLOSURE SIDE WELDMENT S*H50 SPIN RH	-	-	X
3	B3335902	TANK, ENCLOSURE SIDE WELDMENT SG* SPIN RH	X	-	-
3	B3335904	TANK, ENCLOSURE SIDE WELDMENT SE* SPIN RH	-	X	-
4	A3366302	TANK, ENCLOSURE MAGNET BOX BODY SG* SPIN	X	X	X
5	A3366404	TANK, ENCLOSURE MOTOR BOX BODY SE* SPIN	-	X	X
5	A3366402	TANK, ENCLOSURE MOTOR BOX BODY SG* SPIN	X	-	-
6	60174301	MOTOR, STEPPER NEMA34 2.8A SURE STEP	X	X	X
7	60068317	O-RING, VITON 3.063 OD, 2.875 ID	X	X	X
8	A5075001	COUPLE, DRIVE	X	X	X
9	B5305001	ELECTRICAL ASSEMBLY, DVI	X	X	X
10	60022903	WASHER, FLAT #10 SST	X	X	X
11	60022908	WASHER, FLAT #4 SST	X	X	X
12	60088011	SCREW, 4-40 X .250 HEX HEAD SST	X	X	X
13	PP10023	SCREW, 10-24 X .375 SELF TAPPING	X	X	X
14	PP11369	SCREW, SOCKET HEAD .250-20 X .750	X	X	X
15	P0092500	NUTSERT, 10-24 UNC	X	X	X
16	P0142000	NUT, ACORN WITH CENTERLOCK 10-24 SST	X	X	X
17	60135703	BOLT, 10-24 X .375 CARRIAGE SST	X	X	X
18	PP10950	SET SCREW, SLOTED .25-20 UNC, .375L	X	X	X

8.5 Superseded Cover & Damper Assembly built before September 2012

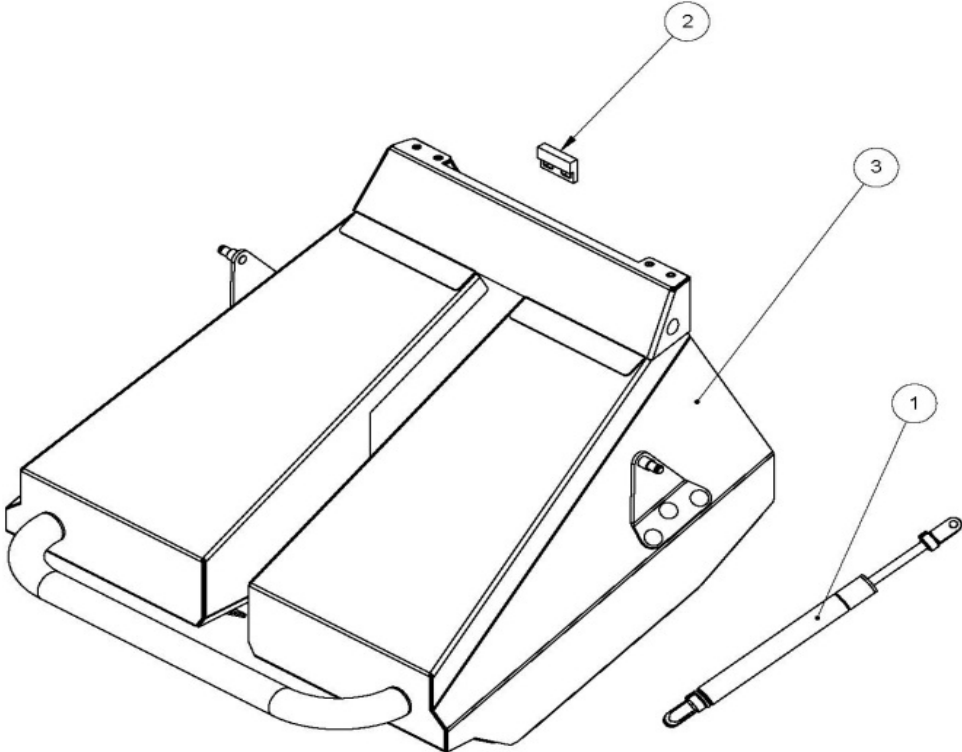

ITEM NO.	PART NO.	DESCRIPTION	SG14 SSH55	SE14	S*H50
1	B2104701	TANK COVER, DAMPER WITH FITTINGS	X	X	X
2	PP10263	SWITCH, PROXIMITY ACTUATOR	X	X	X
3	B2104401	TANK COVER, WELDMENT SG14*	X		
3	B2104402	TANK COVER, WELDMENT SE14		X	
3	B2104403	TANK COVER, WELDMENT S*H50			X

8.6 Cover Assembly built after September 2012

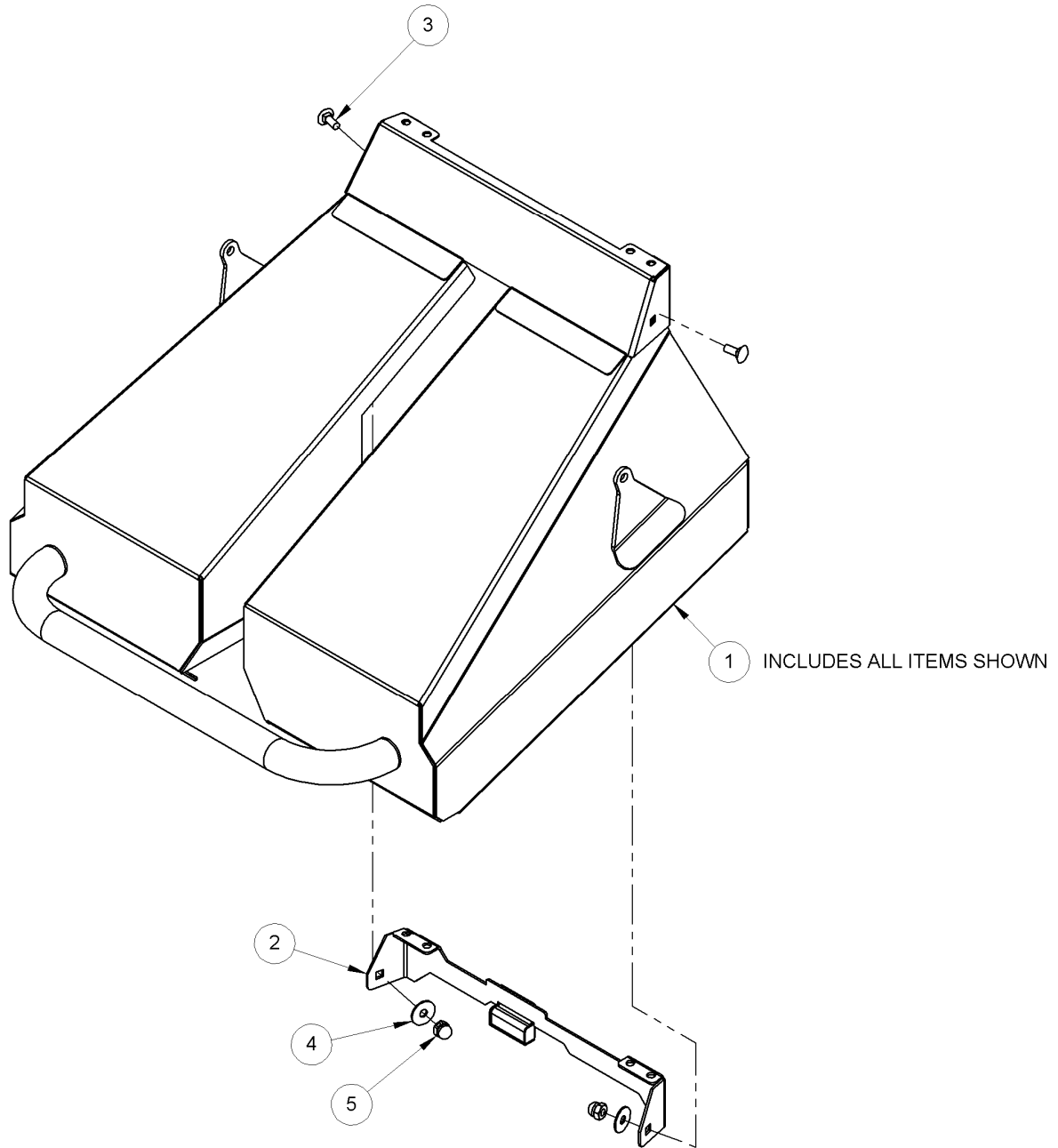

ITEMNO.	PART NO.	DESCRIPTION	SG14 SSH55	SE14	S*H50
1	B2104901	TANK COVER, WELDMENT SG14*	X		
	B2104902	TANK COVER, WELDMENT SE14		X	
	B2104903	TANK COVER, WELDMENT S*H50			X
2	B2105001	TANK COVER, BACK SUPPORT WELDMENT S*14 SPIN	X	X	
	B2105002	TANK COVER, BACK SUPPORT WELDMENT S*H50 SPIN			X
3	60135702	BOLT, 10-24 X .500 CARRIAGE SST	X	X	X
4	60022903	WASHER, FLAT #10 SST	X	X	X
5	P0142000	NUT, ACORN WITH CENTERLOCK 10-24 SST		X	X

8.7 Miscellaneous Parts

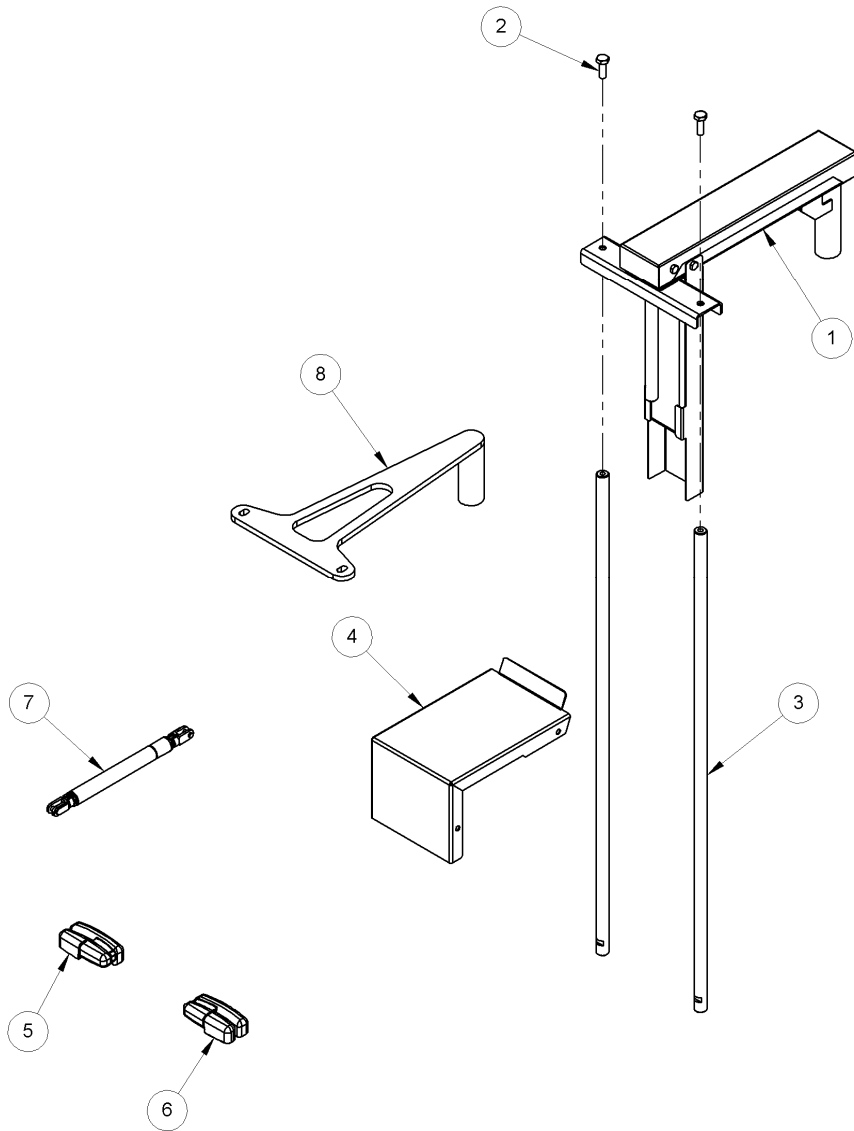

ITEM NO.	PART NO.	DESCRIPTION	SG14	SG14R SSH55	SE14	S*H50
1	B5609901	BASKET LIFT, TOP PLATE ASSEMBLY SG14R, SSH55		X		
	B5609902	BASKET LIFT, TOP PLATE ASSEMBLY SG14	X			
	B5609903	BASKET LIFT, TOP PLATE ASSEMBLY SE14			X	
	B5609904	BASKET LIFT, TOP PLATE ASSEMBLY S*H50				X
2	60088003	SCREW, .250-20 X .750 HEX HEAD SST	X	X	X	X
3	A5624902	BASKET LIFT, ROD SG SPIN	X	X	X	X
4	A3366502	TANK, ENCLOSURE MOTOR COVER SG* SPIN	X	X		
	A3366504	TANK, ENCLOSURE MOTOR COVER SE* SPIN			X	X
5	60176901	HINGE, LIFT OFF BRIGHT CHROME TYPE A	X	X	X	X
6	60176902	HINGE, LIFT OFF BRIGHT CHROME TYPE B	X	X	X	X
7	B2104702	TANK COVER, DAMPER WITH FITTINGS	X	X	X	X
	B2104701	FOR UNITS BUILT PRIOR TO 9/2012				
8		OBSOLETE, REPLACE WITH ITEM 1	X	X	X	X

8.8 Basket Assembly

B4516001 Entire assembly (Blue Handle)

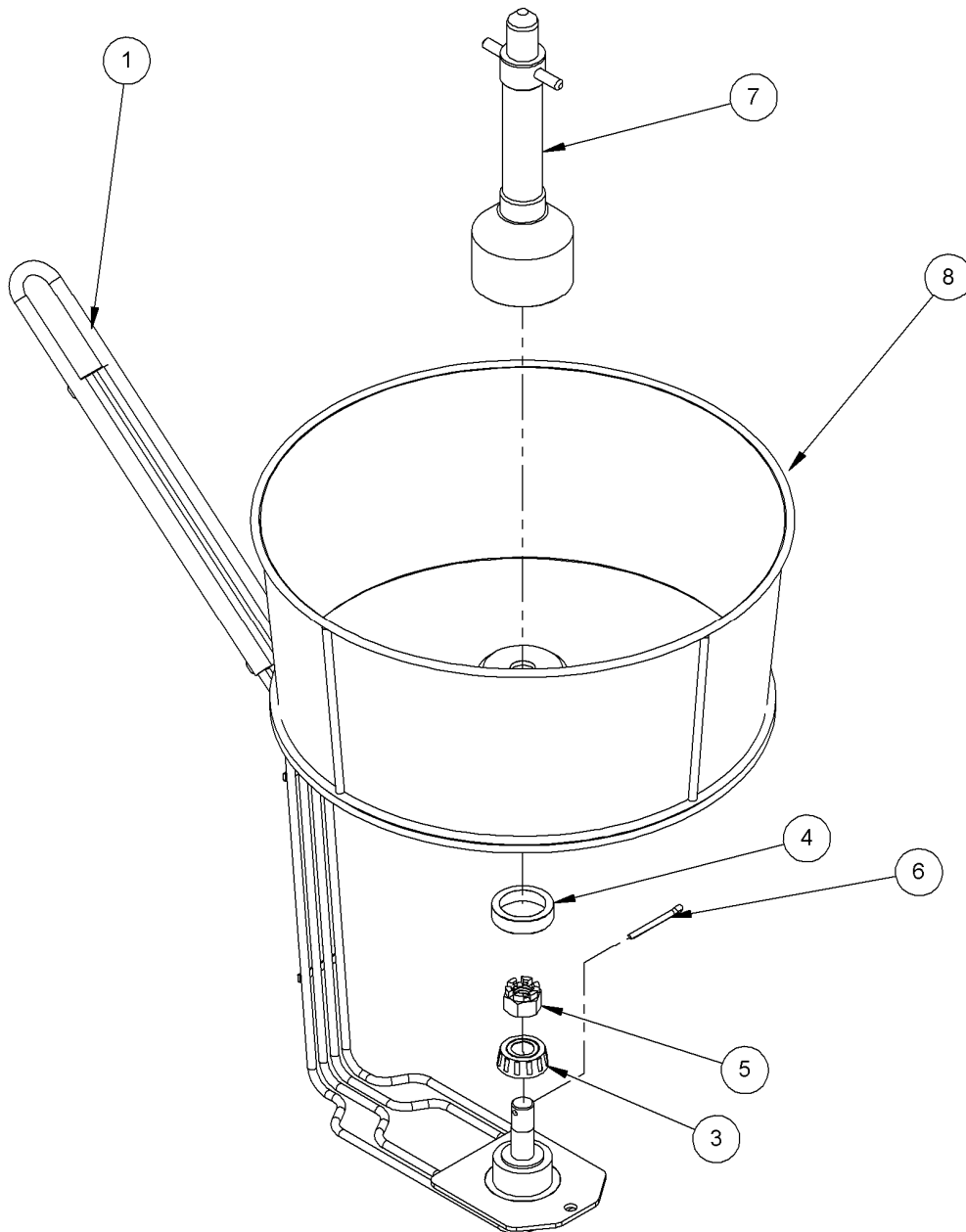

ITEM NO.	PART NO.	DESCRIPTION
1	B4515303	WIRE GOODS, BEARING BASKET HANDLE WELDMENT BLUE
2	B4515304	WIRE GOODS, BEARING BASKET HANDLE WELDMENT GREEN
3	60183801	TAPERED ROLLER BEARING ASSEMBLY, BEARING 1.375 O.D. X .500 I.D.
4	60183901	TAPERED ROLLER BEARING ASSEMBLY, OUTER RING (RACER) 1.375 O.D. X .500 I.D.
5	60183501	NUT, SLOTTED HEX (CASTLE) .50-13 THREAD
6	6NT202	PIN, SST COTTER .125 DIA X 1.25 LG.
7	B4515801	WIRE GOODS, SPIN BASKET DRIVE POST ASSEMBLY
8	B4515901	WIRE GOODS, SPIN BASKET WELDMENT

8.9 Bottom Assembly

B5608802 Entire assembly

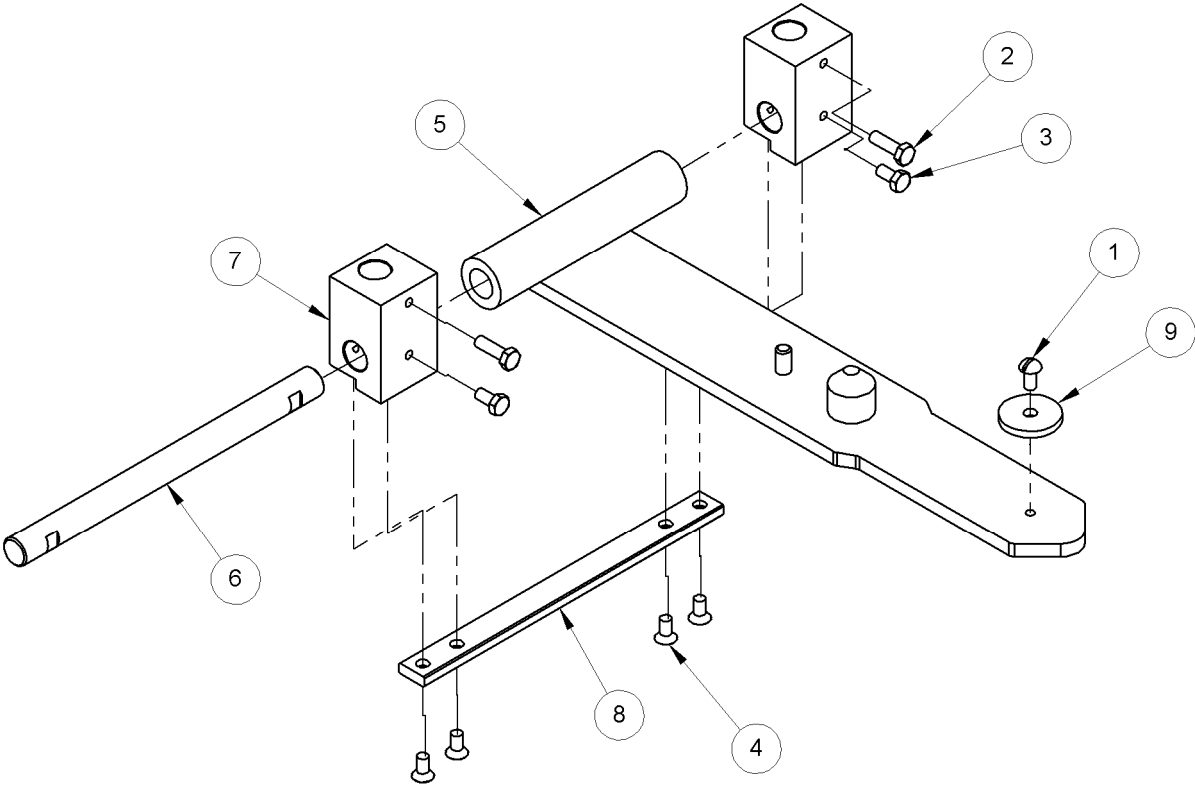

ITEM NO.	PART NO.	DESCRIPTION
1	PP10665	SCREW,10-24 X .375 RDH SST
2	60088013	SCREW, 10-24 X .625 HEX HEAD SST
3	60088012	SCREW, 10-24 X .375 HEX HEAD SST
4	60177401	SCREW, OVAL 82 DEG X .375 SST
5	B5609001	LIFT PLATE
6	A5625402	LIFT PLATE, PIVOT BAR
7	A5625302	LIFT PLATE,BLOCK
8	A5625502	LIFT PLATE STOP
9	60022906	WASHER, FLAT #10 X 1.00 X .125 THK SST

8.10 Splash Back Assembly

B41043xx Entire assembly

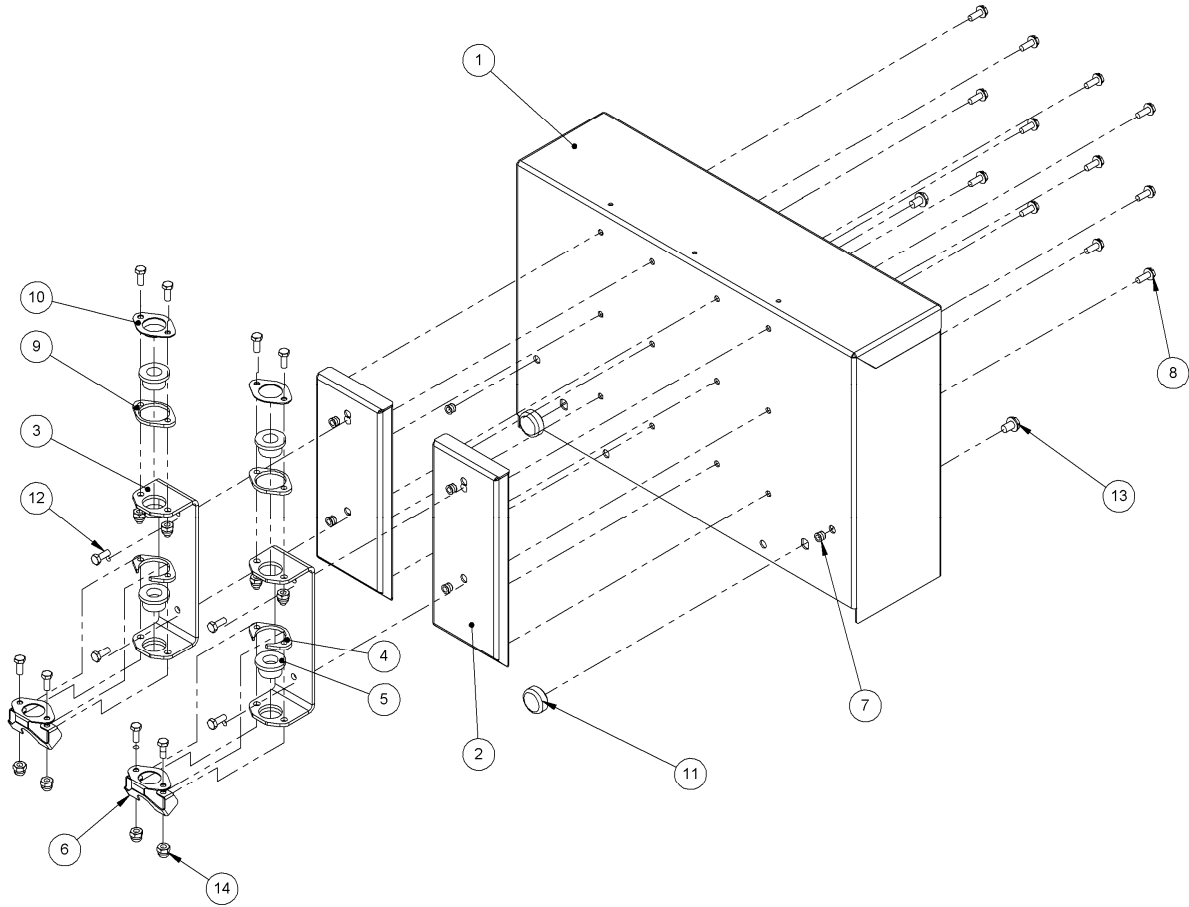

ITEM NO.	PART NO.	DESCRIPTION	SG14 SSH55	SE14	SGH50	SEH50
1	A4113102	SPLASH BACK, SPIN SG14* SINGLE	X			
	A4113108	SPLASH BACK, SPIN SEH50 SINGLE				X
	A4113106	SPLASH BACK, SPIN SGH50 SINGLE			X	
	A4113104	SPLASH BACK, SPIN SE14 SINGLE		X		
2	A5625702	BASKET LIFT, ROD GUIDE BOX BODY SG14* SPIN	X			
	A5625704	BASKET LIFT, ROD GUIDE BOX BODY SE14* SPIN		X		
	A5625706	BASKET LIFT, ROD GUIDE BOX BODY S*H50 SPIN			X	X
3	A5625002	BRACKET, ROD BEARINGS	X	X	X	X
4	A5626702	RING, ROD BEARINGS INNER BOT	X	X	X	X
5	60054903	BEARING, PTFE .5 ID	X	X	X	X
6	A5626602	DEFLECTOR, ROD GUIDE	X	X	X	X
7	P0092500	NUTSERT, 10-24 UNC	X	X	X	X
8	P0075400	SCREW, 10-24 X .500 SELF TAPPING	X	X	X	X
9	A5625202	RING, ROD BEARINGS INNER	X	X	X	X
10	A5625102	RING, ROD BEARINGS	X	X	X	X
11	60132001	TANK, STUD SPLASH BACK SCREW ON		X		X
12	P0112000	SCREW, 10-24 X .500 HEX HEAD SST	X	X	X	X
13	60118201	SCREW, .250-20 X .375 HEX FLANGED HEAD SST		X		X
14	P0142000	NUT, ACORN WITH CENTERLOCK 10-24 SST	X	X	X	X

9 Basket Lift Wiring Diagram

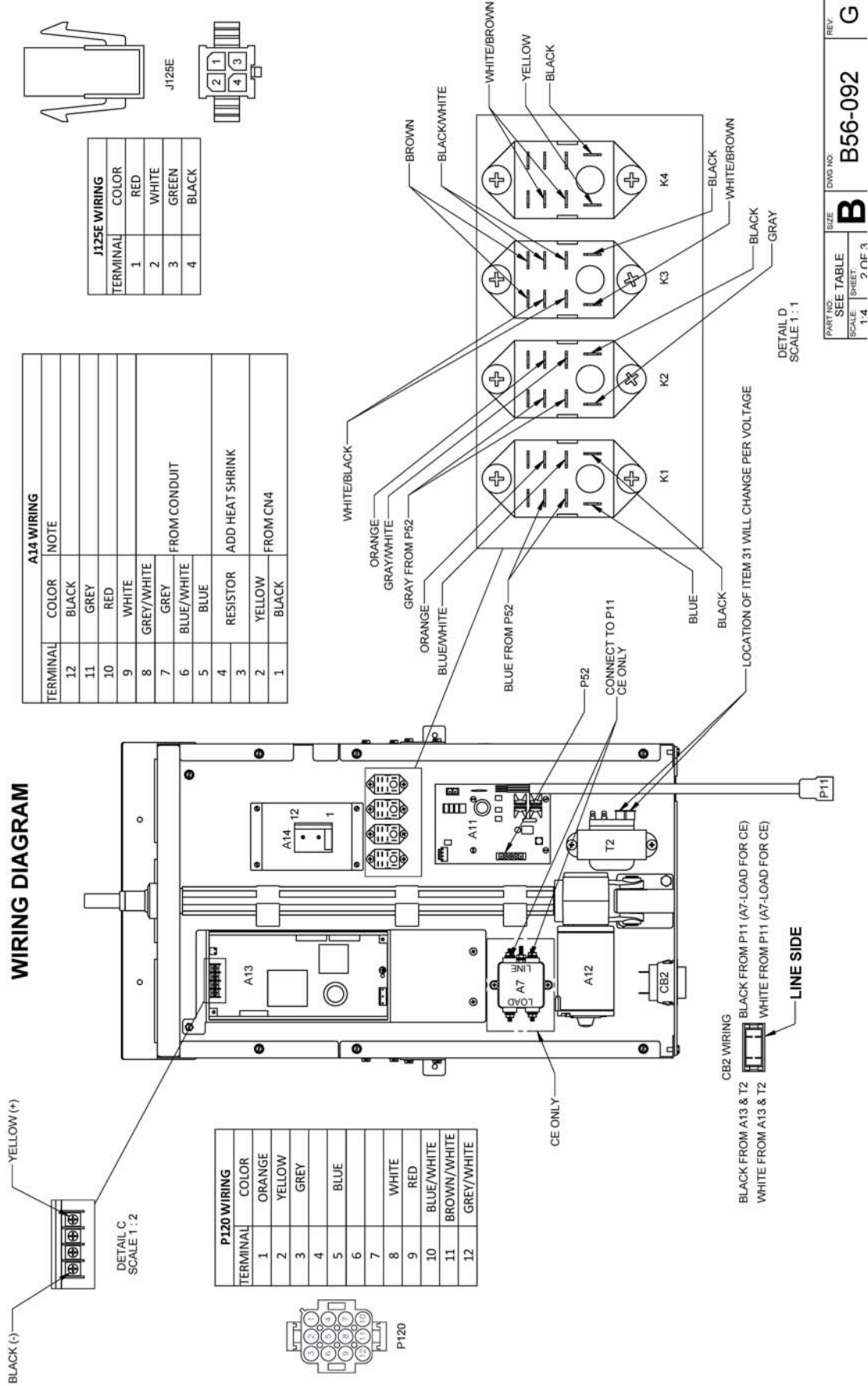

Notes:

Notes:

In the event of problems with or questions about your order, please contact the Factory at:

+001 (603) 225-6684 (World Wide)

In the event of problems with or questions about your equipment, please contact the Pitco Authorized Service and Parts representative (ASAP) covering your area, or contact Pitco at the number listed to the left.

MAILING ADDRESS – P.O. BOX 501, CONCORD, NH 03302-0501
SHIPPING ADDRESS – 10 FERRY ST., CONCORD, NH 03301

SPINFRESH™ is a trademark of Spintry inc.